

THIS DWG. IS SOLE PROPERTY OF NEOMETRIX ENGINEERING PVT. LTD. UNAUTHORISED USE OF THIS DWG. OR MAKING PRODUCT AS PER THIS DWG. WITHOUT OUR PERMISSION OR ANY OTHER MISUSE IS NOT PERMITTED.

TANK DETAILS :-

DIMENSIONS-

LENGTH: 1300 mm
 WIDTH: 1200 mm
 HEIGHT: 420 mm

MATERIAL-

MILD STEEL

CAPACITY-

650 LITERS

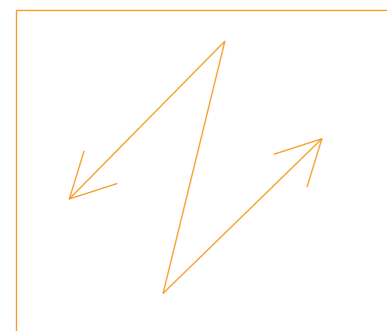

16.0

Spare Inlet 3/4" BSPF (PORT, QTY: 01 NOS.)
 Spare Inlet 3/4" BSF (PORT, QTY: 01 NOS.)
 Return Oil from wall mounted bearing housing 3/4" BSPF (PORT, QTY: 01 NOS.)
 Return Oil from wall mounted bearing housing 3/4" BSPF (PORT, QTY: 01 NOS.)
 Return Oil from drive bearing housing 2" BSPF (PORT, QTY: 01 NOS.)
 Return oil from support bearing housing 2" BSPF (PORT, QTY: 01 NOS.)

RETURN LINE MANIFOLD

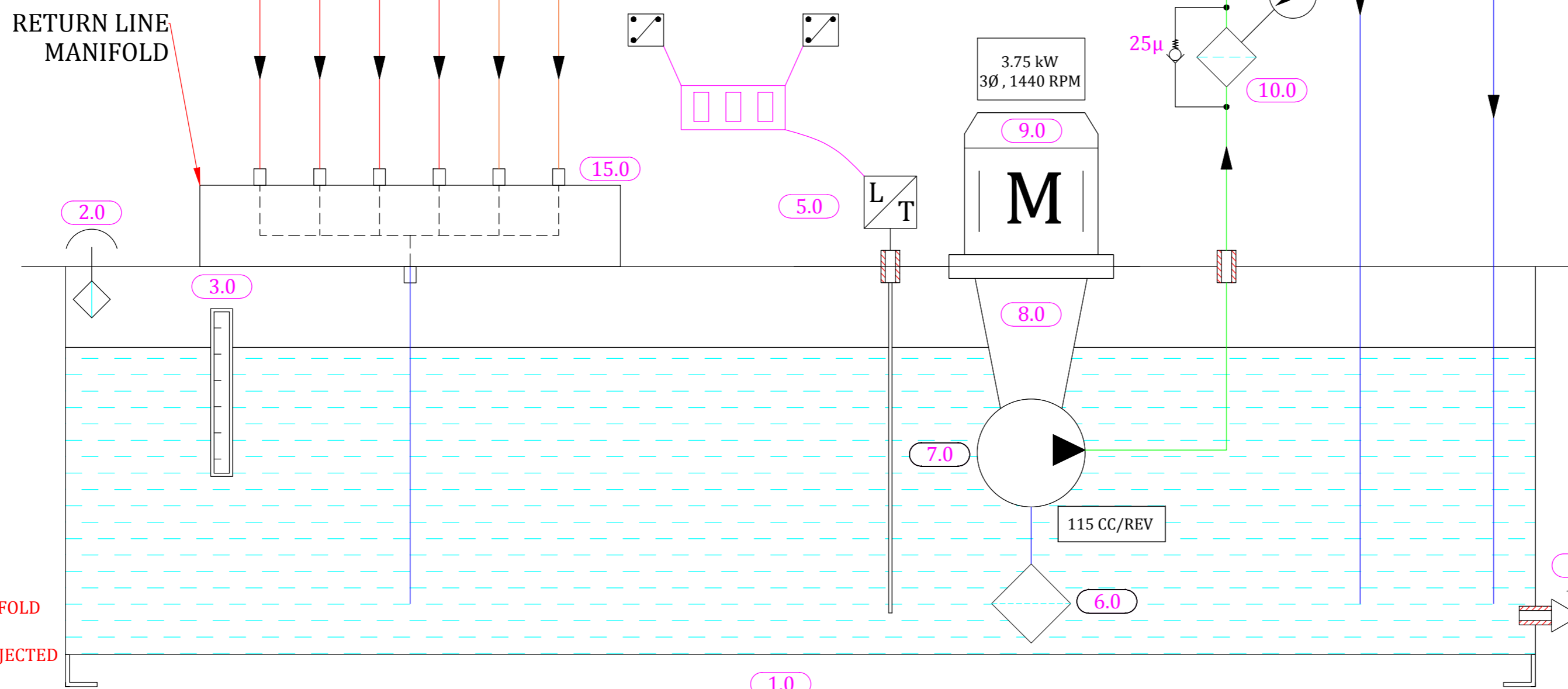

PART DESCRIPTION	
PART NO.	PART NAME
1.	HYDRAULIC TANK
2.	FILLER BREATHER
3.	LEVEL INDICATOR
4.	DRAIN VALVE
5.	LEVEL TRANSMITTER
6.	SUCTION STRAINER
7.	HYDRAULIC PUMP
8.	BELL HOUSING
9.	ELECTRIC MOTOR
10.	FILTER (25 μ)
11.	FILTER (10 μ)
12.	PRESSURE GAUGE
13.	BALL VALVE
14.	NON RETURN VALVE
15.	RETURN LINE MANIFOLD
16.	CONTROL PANEL

RETURN OIL LUBRICATION SYSTEM

NOTE:

- ALL FITTINGS, PIPE & MANIFOLD ARE OF MILD STEEL.
- TENTATIVE DRAWING, SUBJECTED TO CHANGED.

		NEOMETRIX ENGINEERING PVT. LTD. E-148, Sector-63, Noida, UP-201301 Tel. No. :- 0120-4500800 Fax No. :- 0120-4500888 Email :- contact@neometrixgroup.com	
MAIN TITLE	1000HP CSTF LUBRICATION SYSTEM	Q.A No.	
SUB - TITLE	HYDRAULIC CIRCUIT DIAGRAM	Cross Ref. Doc. No.	
CODE	A1758	Customer Dwg./Ref. No.	
CUSTOMER	GTRE, BANGLORE	Note:	
END - USER	GTRE, BANGLORE		
TENDER NO.	GTRE/MMG/BMR2/2028/17	DATED:	31/07/17
PROJECTION	DRAWN BY & DATE	N.K	18/07/2018
CHECKED BY & DATE	S.R	18/07/2018	Size Scale Sheet No. Of
APPROVED BY & DATE	S.P.S	18/07/2018	A4 NTS 01 01
			NEO. DWG. No.
			T-DAP-HDWG-A1758
			REV
			01